

**Easy, step-by-step,
underground sprinkler
system layout guide**

**FREE SPRINKLER
SYSTEM DESIGN**

See page 5 for details

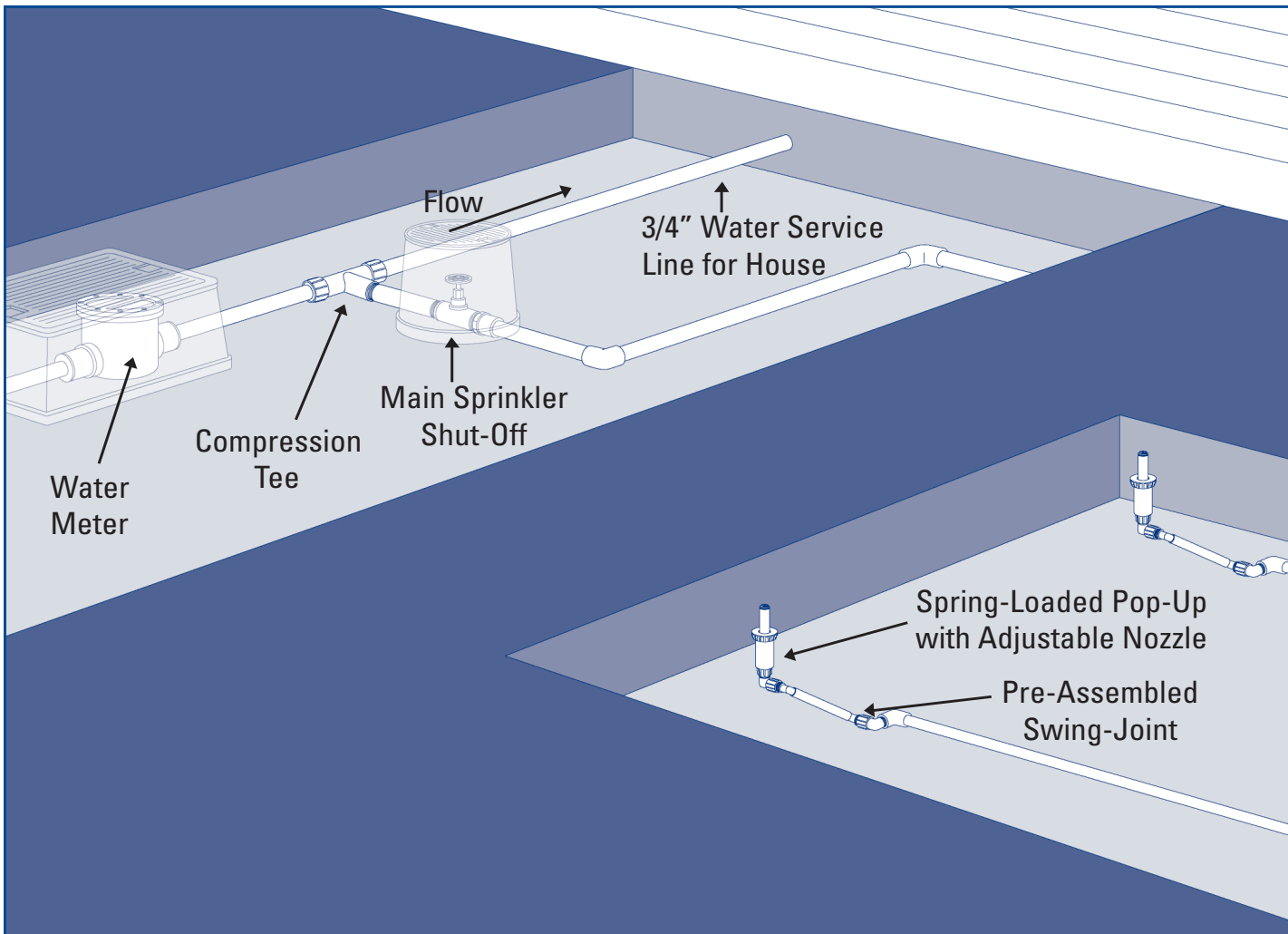



WHY INSTALL AN UNDERGROUND IRRIGATION SYSTEM?

1

- **Conserve Water & Money** – Reduce over-watering and water when evaporation levels are low.
- **Save Time** – Enjoy a beautiful yard and spend more time doing the things you like.
- **Increase Property Value** – Greener, thicker lawns, shrubs and trees, make your property more attractive.
- **Eliminate Yard Clutter** – Eliminate the ugly tangle and yellow marks left by unsightly garden hose.

CHECK LOCAL CODES

2

Water District

Call your local water district for requirements concerning permits, plumbers, backflow prevention and pipe requirements.

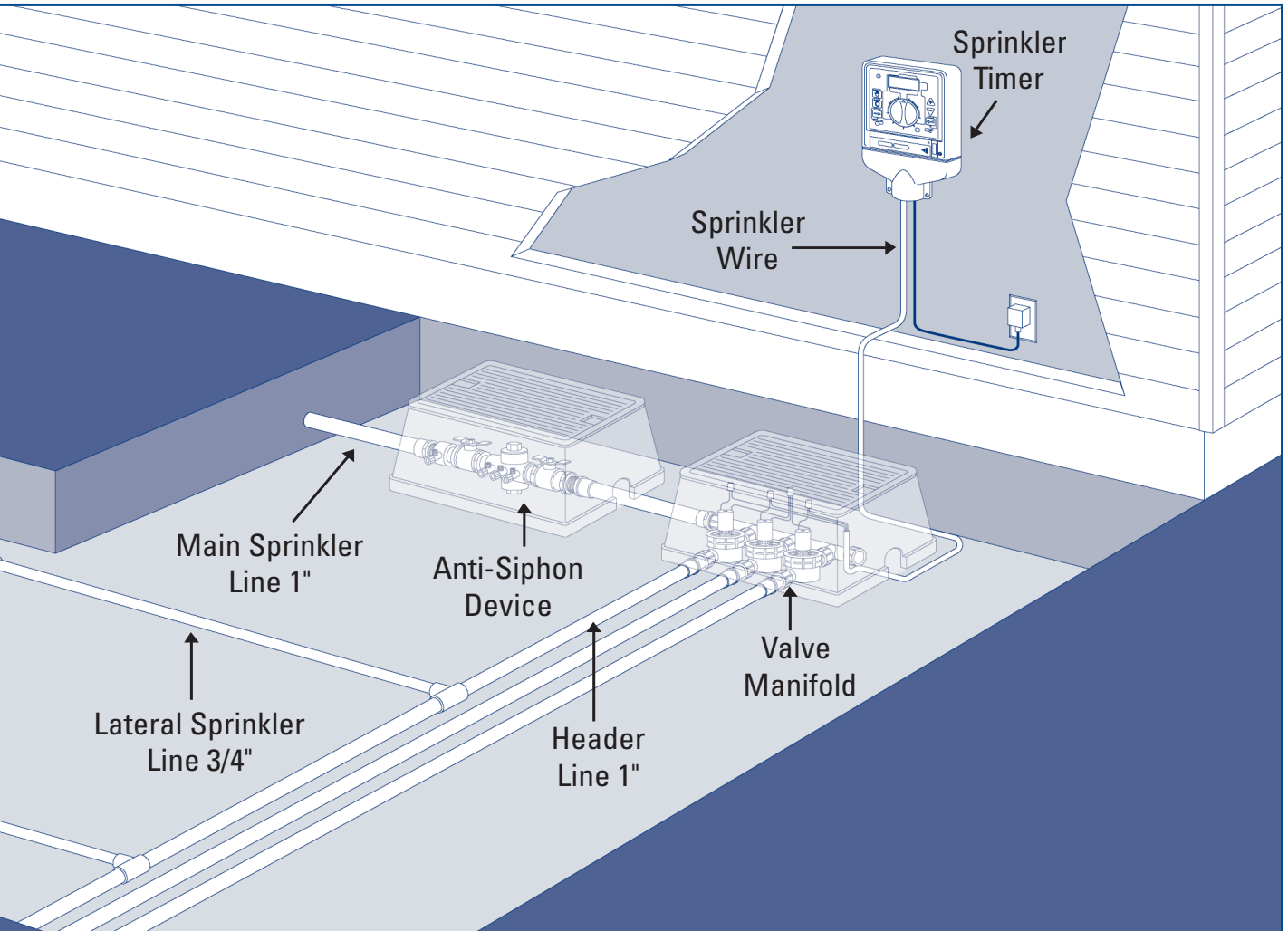

Common Questions To Ask Your Water District:

- Is a permit required? Yes No
- Is a licensed plumber required for connecting to the main water supply?
 Yes No
- What type of backflow prevention device is required?
 Double Check Pressure Vacuum Breaker
 Automatic Anti-siphon Valve Dual Check Valve
- Climate: Will pipes freeze in my area?
 Freezing Non Freezing
- How deep should I bury my pipes?
 Pipe Depth _____
- What type of pipe is required (or recommended) for my area?
 Pipe type: _____

Utility Companies

Before digging, contact your local gas, power, telephone, and cable companies to mark underground cables and pipelines on your property, such as:

- Gas Power Other _____
- Phone TV & Internet cables

MEASURE WATER FLOW

3

You need to determine the available water flow for your sprinkler system so you'll know how many sprinkler heads can run at one time. Water flow is measured in gallons per minute or GPM.

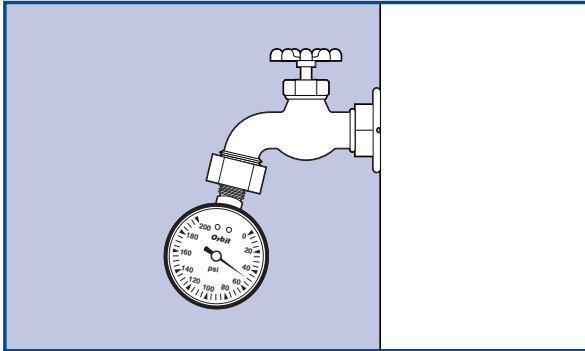

Measure Your Water Pressure

- Attach an Orbit® pressure gauge (part # O-91130) to an unregulated outside faucet*. *Unregulated means a line without a pressure regulator.*
- Open the faucet and record the reading on the gauge. *No water should be running during the test.*

PSI _____

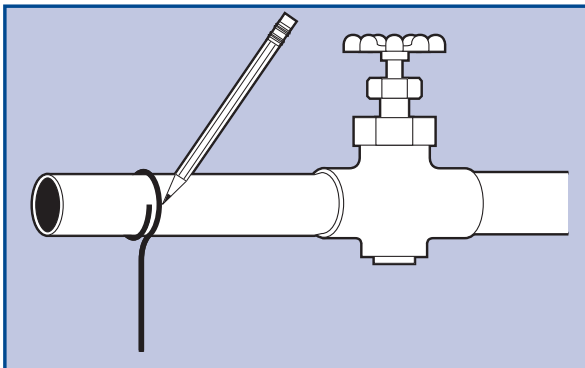

Measure the Main Water Service Line

- Wrap a piece of string around your main water service line then measure the length of the string.
- Use the table to convert the string length to pipe size (diameter).

Note: The main water service line is the pipe that runs from the water meter to the house. If you're connecting to a line other than the main line, measure the line that you will be connecting to.

DETERMINE SIZE OF SERVICE LINE

Length of string	2"	2-3/4"	3-1/4"	3-1/2"	4-1/4"
Copper pipe size	1/2"	3/4"		1"	
PVC or galvanized pipe size		1/2"	3/4"		1"

Pipe Size _____

WATER PRESSURE (PSI)									
MAIN LINE SIZE	35 LB.	40 LB.	45 LB.	50 LB.	55 LB.	60 LB.	65 LB.	70 LB.	75 LB.
1/2"	3.5	5.0	6.0	6.5	7.0	7.5	8.0	9.0	9.5
3/4"	7.5	9.0	10.0	12.0	13.0	14.0	15.0	16.0	17.5
1"	10.0	11.5	13.5	15.0	16.0	17.5	18.5	20.0	21.0

System Capacity

Use the main line pipe size and pressure (PSI) taken to determine the gallons per minute (GPM) capacity of your system.

GPM Capacity _____

* If an unregulated faucet is unavailable, call the local water district for an estimated PSI.

Important: If your water pressure exceeds 80 PSI, use a pressure reducer. Excessive pressure may damage system.

MEASURE & DRAW PROPERTY

4

Measure your property and create a top down view on graph paper (supplied in this guide). Make the drawing to scale. For example, each one-inch square represents 10 feet on the graph paper, or each small square = 1 foot.

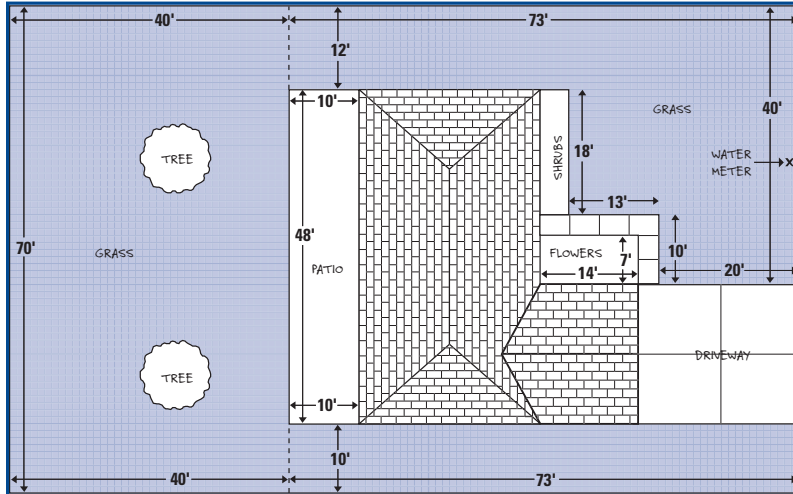

Draw Property to Scale.

Include:
Buildings, sidewalks, patios, driveways and trees

Label:
Grass, flower beds and water meter location

LET ORBIT® DESIGN YOUR SPRINKLER SYSTEM



TIME SAVING TIP!

Instead of continuing on to the next section, go to www.orbitonline.com and use the free sprinkler system design program.

What you receive:

- Detailed color-coded drawings with:
 - Sprinkler placement and spray patterns
 - Layouts of individual sprinkler zones/stations
 - Valve and sprinkler pipe placement.
- Step by step assembly instructions.
- Detailed parts list for PVC or Poly-Pipe systems.
- Quick turn around – Completed in about 2 days.

SELECT HEADS

5

Select sprinkler heads you would like to use for each area and make a note of each type on your drawing.

Select Head Type for Each Section

Sprinklers are generally divided into three categories:

- **Large Area Sprinklers**
Areas larger than 25' x 25'
- **Medium Area Sprinklers**
Areas smaller than 25' x 25'
- **Small Area Sprinklers**
Areas with flowers, shrubs, and ground cover

Note: Refer to page 22 (Selecting Your Products) to determine the best sprinkler for your yard.

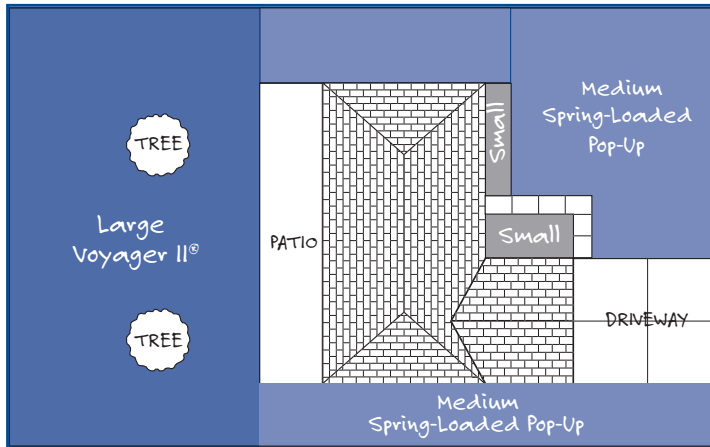

Select Heads For Each Area

Our example uses:

- Voyager II® in the back yard
- Spring-Loaded Pop-Up (with adjustable nozzle) in the front and side yard
- Mushroom bubblers in the front flower areas

Large Area Heads

For large open areas such as backyards and play areas. Space heads 15' to 45' apart (depending on sprinkler type).

- **Gear Drive** – Voyager II® and Saturn III®
 - Easy to adjust
 - Produces a smooth quiet rotating spray
 - Closed case design resists clogging from grit, sand and heavy grasses
- **Impact** (Satellite® and 1/2" Brass Impact)
 - Simple and reliable flow-through design that utilizes an efficient impact mechanism

OR-94161-55661



Voyager II® – Spaced 20' to 40'

OR-94214T



OR-SATURN-PRO

Saturn III® – Spaced 15' to 30'

OG-55201



Satellite® – Spaced 25' to 45'



OS-ECOSPRAY

Medium Area Heads
Pop-up heads & Flush heads
Spacing: 10 to 15 feet

Medium Area Heads

Commonly used in front and side yards.

- Spring-Loaded Pop-Up with adjustable pattern
 - Easy to adjust pattern 25° - 360°
- Spring-Loaded Pop-Up with fixed pattern
 - Available in Full, 1/2, 1/4 and strip pattern nozzle

Small Area Heads

Commonly used for flooding flower beds and ground cover or to spot water trees and shrubs.

- Mushroom Bubbler II™
 - Adjustable flow
- Small Area Heads
Stream & Bubbler heads
Spacing: 3 to 5 feet

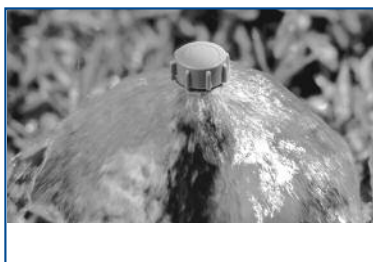

Note: Orbit® DripMaster® is a water saving alternative to small area heads. Go to www.orbitonline.com for more information.

PLAN HEAD PLACEMENT

6

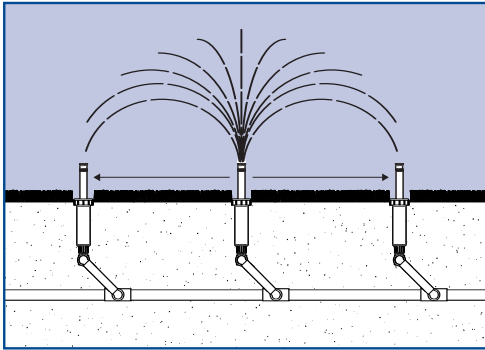

Head to Head Coverage

Proper sprinkler placement allows even watering and reduces dry patches.

Proper placement requires:

- **Head to head coverage:** Each sprinkler should spray to the head beside and across it.
- **Equal spacing between heads:** Permits uniform water distribution.

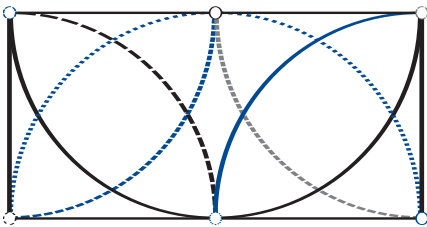

Placement Example: Good

- Good Overlap
- Head to head coverage

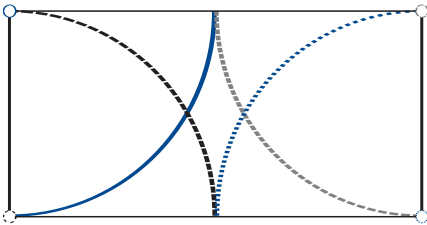

Placement Example: Bad

There is not enough overlap. The center is not getting water.

- Not enough overlap
- No coverage in center



Narrow Strips

On narrow strips of grass use strip pattern spray heads and space them evenly apart. These heads may be used for narrow strips up to 4 feet wide.

Evenly space strip heads on narrow sections.

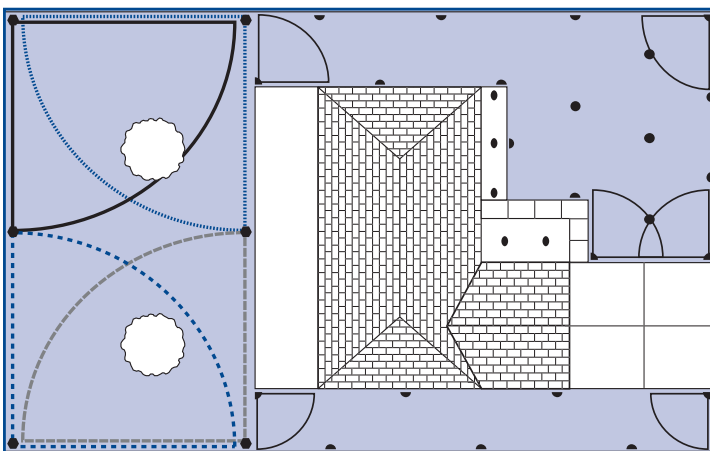

Place Heads in Corners

- Begin by placing a sprinkler in each corner on your drawing.
- Use a compass to draw the spray pattern.

Note: Use chart 2 on page 20 to obtain spray distance.

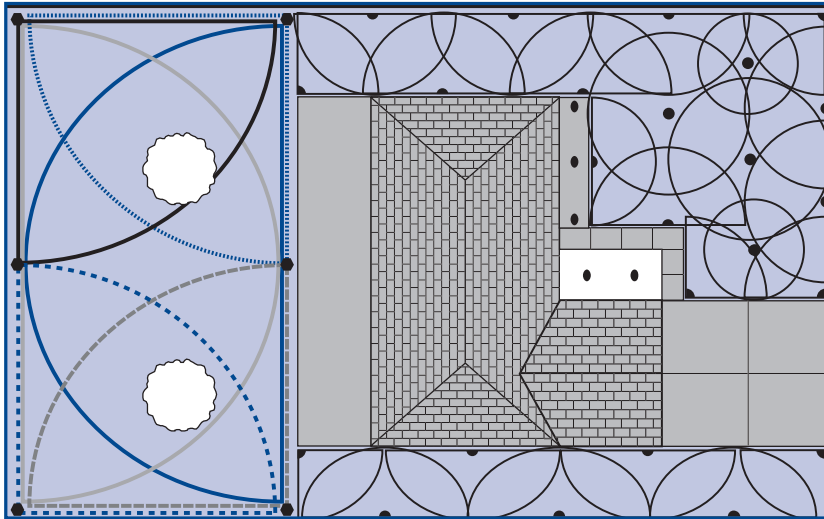

Add Heads and Adjust Spacing

- Add sprinklers along the sides or center to increase coverage.

CREATING WATERING ZONES OR STATIONS

7

A watering zone or station consists of a group of sprinklers attached to one valve. The number of heads per zone will be determined in this section.

Purpose of Zones

Zones are designed to:

- Maintain adequate water flow for optimal spray coverage (Avoid dry patches)
- Separate areas based on watering requirements
 - Shade vs. Full Sun Areas
 - Lawn vs. Shrubs

Important:

- Do not mix sprinkler types in the same zone (e.g. Gear Drive, Impacts, Pop-Ups and Bubblers)
- Do not exceed the maximum sprinkler heads recommended per zone
- Use the recommended pipe size in this guide. Smaller diameter pipe will decrease the water flow.

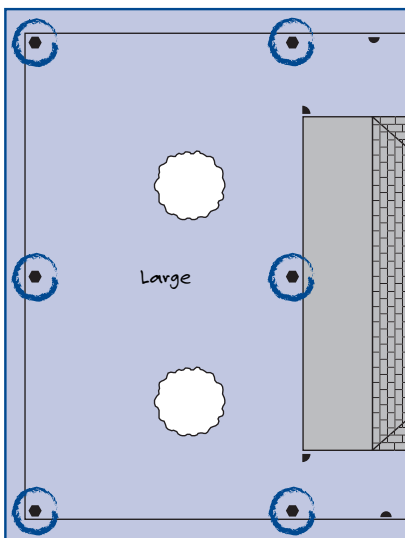

Large area heads circled

Group Heads of Same Type in the Same Area

Starting with large area heads, use the following example as a guide.

- Identify all large area heads on your drawing.

Divide Large Area Heads into Zones

STEP 1: Maximum Heads Per Zone

Use the following information (collected earlier) to determine zone capacity:

- Main Line Size
- Water Pressure (PSI)
- Large area head selected

Use Orbit's® Quick Reference (Chart 1, Page 20) to determine the maximum heads per zone for your sprinkler system.

QUICK REFERENCE – MAXIMUM HEADS PER ZONE ESTIMATES					
MAIN LINE SIZE	WATER PRESSURE (PSI)				
	SCH. 40 PVC	Gear Drive	30 PSI	40 PSI	50 PSI
	Voyager II®	1	2	2	3
	Saturn III®	2	2	3	4

Example – We have determined that our home has a “Main Line” size of 3/4” with a “Static Water Pressure” of 60 psi. Based on this information, and using the Quick Reference, we see that we cannot use more than three Voyager II® sprinklers in the same zone.

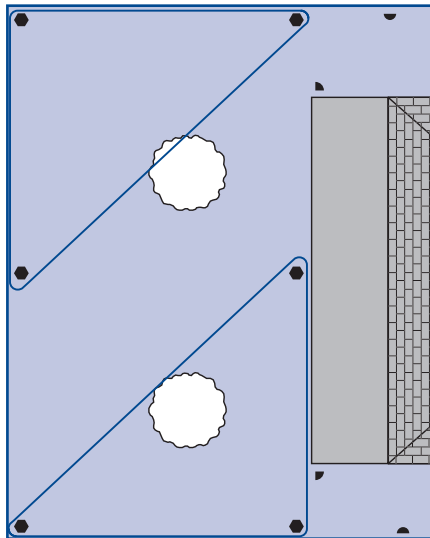

STEP 2: Identifying Sprinklers in a Zone

Begin grouping large area heads, ensure you do not exceed your “Maximum Heads per zone number.”

Example – Since we determined (in our example above) that 3 Voyager II® heads is the maximum zone capacity, we grouped all large area heads into 2 zones.

Step 3: Medium and Small Area Head Zones

Repeat steps 1 & 2 to determine and identify zones for Medium Areas Heads. Repeat again for Small Area Heads.

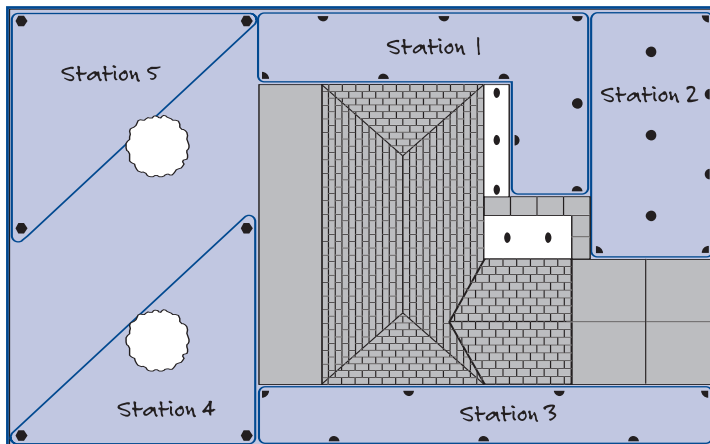

Step 4: Number Each Zone

- Assign a number to each zone.

PLAN VALVE PLACEMENT

8

You'll need to select a location for your main shut-off valve and the best location for the sprinkler valve manifold.

Main Shut-Off Valve

The Main Sprinkler Shut-Off valve is the valve that shuts off water to the entire sprinkler system. Connection to the main water supply is “downstream” of your water meter. Mark the location on your plan.

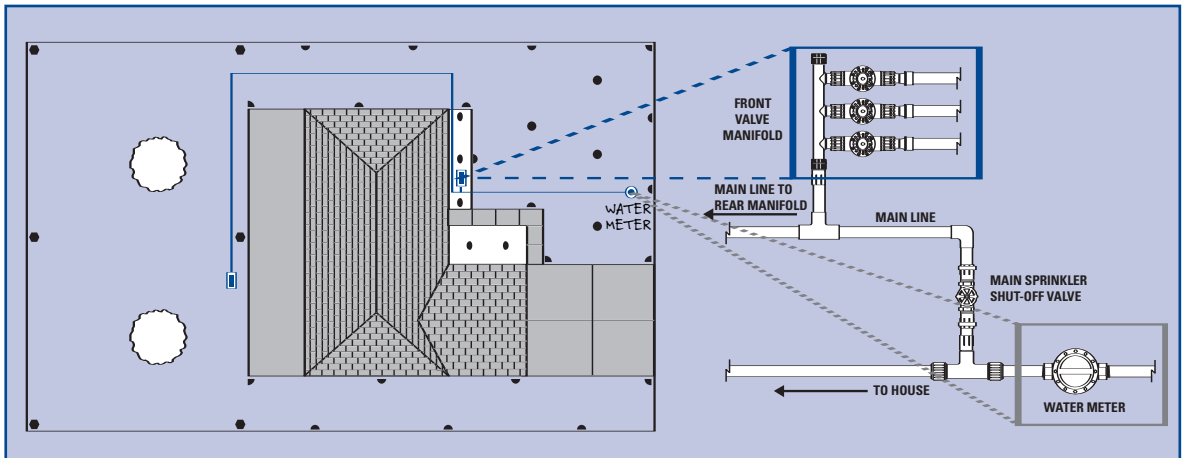

Valve Manifold Location

One valve will be used for each zone. Valves that are grouped together are called a manifold. It's common to install one manifold in the front yard and one in back.

Mark the Location on Your Plan

Tip: The valve manifold(s) should be installed in an accessible location, away from heavy foot traffic, where it is easy to operate and service. It's also a good idea to locate the manifold on elevated ground, to avoid water accumulating around the valves.

Plan Backflow Prevention

A backflow prevention device is used to stop foreign material from siphoning back into the main water supply. The local code information you gathered from your water district should include the type of device to install and where and how it should be installed. Plan a location for your backflow prevention device and draw it on your layout.

Three common types

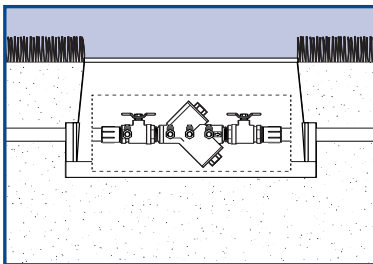

Double Check

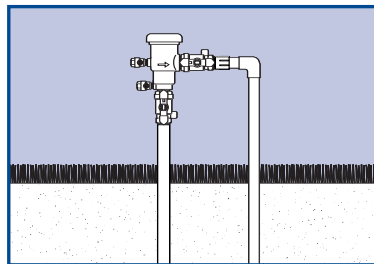

Pressure Vacuum Breaker

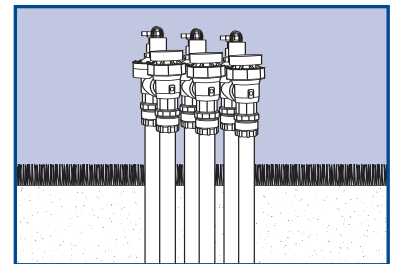

Automatic Anti-Siphon Valve

Note: For certain Canadian areas Dual Check Valves are used

DIAGRAM PIPE LAYOUT

9

You need to plan and draw the layout for your main sprinkler line and lines for each zone.

Main Sprinkler Line

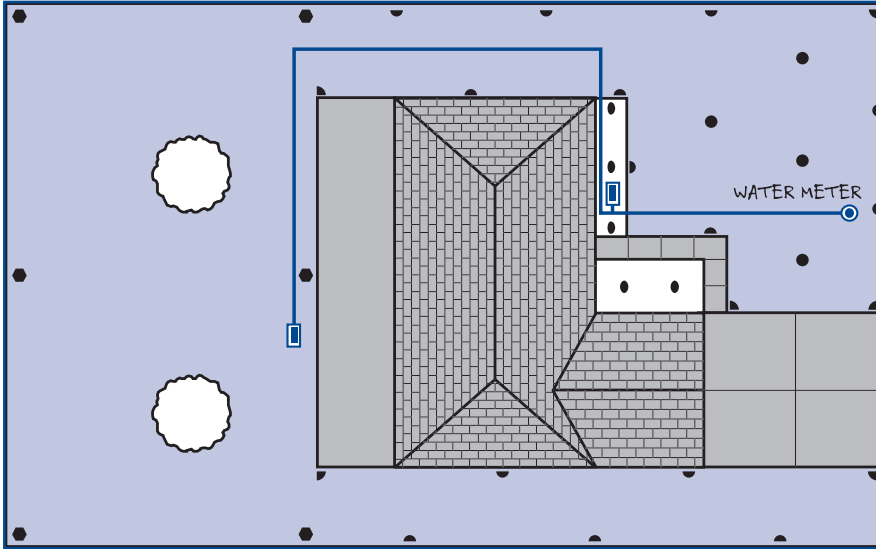

Draw the Main Sprinkler Line Route

Use a direct route to draw the main sprinkler line from the main shut-off valve to the front and back yard manifolds.

Important: Your main sprinkler line should be 1 size larger than the water main supply line.

Header and Lateral Lines Guidelines

Header lines – Attaches to a valve and supplies water to the lateral lines

- Do not use pipe smaller than 1"
- Do not attach sprinklers to this line

Lateral lines – Pipe that branches off from the header line and supply water to the sprinkler heads

- Do not use pipe smaller than 3/4"

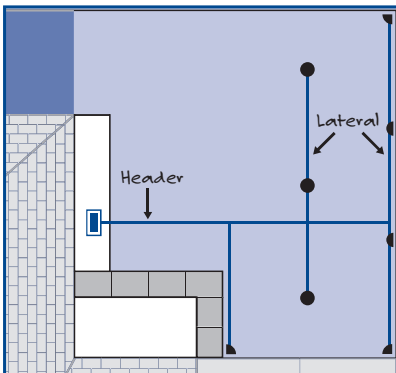

Good Layout Example

This is a good layout because the water is evenly distributed between the lateral lines and individual sprinklers.

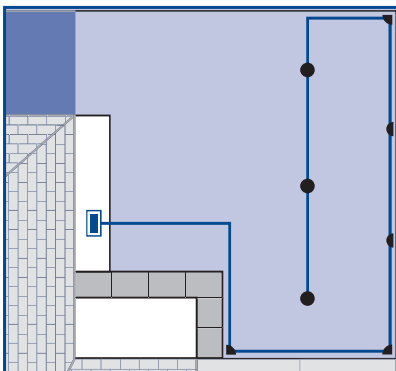

Bad Layout Example

This is a bad layout because there is no header line. The sprinkler heads, located at the end of the line, will have less water pressure than the heads located closer to the valve.

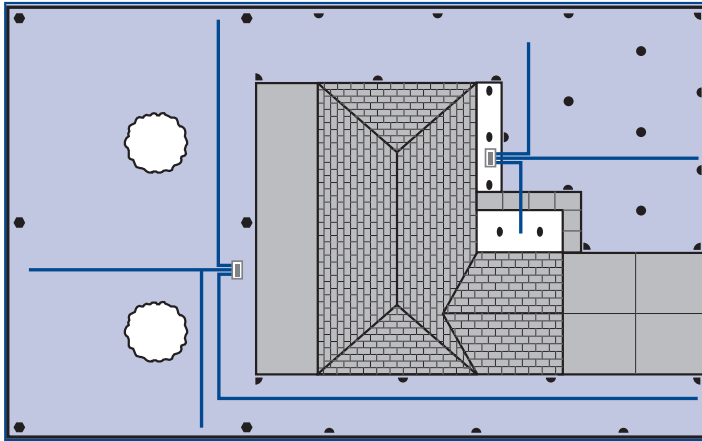

Header Line

Draw a header line from the manifold to each zone. Header lines will be intersected with lateral lines. Sprinkler heads should not be installed on this line.

Use 1" Pipe

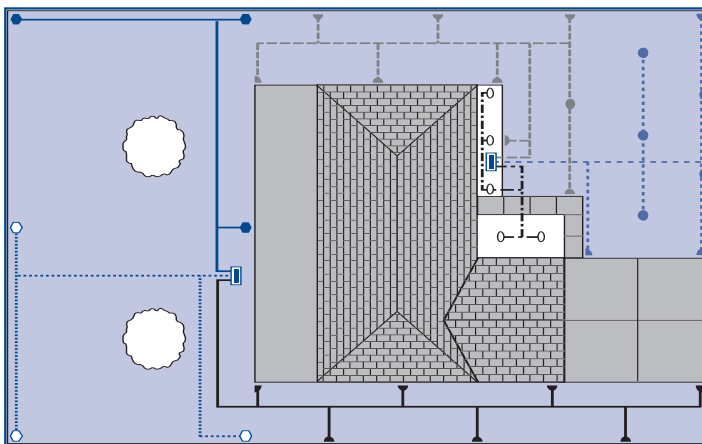

Lateral Lines

Draw lateral lines that connect the header line to sprinkler heads. These lines should be branching, not circular.

Use 3/4" pipe

PLAN TIMER LOCATION

10

Select a location near a power source and where it's easy to access. You'll need to be able to run sprinkler wire to each valve. If you select a location outside, the timer should be made for outdoor mounting or protected with a weather resistant box.

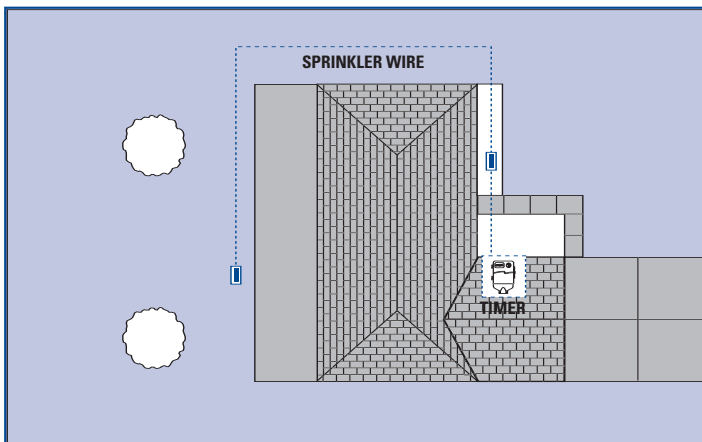

Timer Placement & Sprinkler Wire Route

- Mark the planned location for the sprinkler timer
- Draw the route the sprinkler wire will use to connect the timer to the front and rear manifolds

System Layout Graph Paper

Helpful Tools

Planning

- | | |
|--------------------------------|---------------|
| _____ 50' or 100' Tape Measure | _____ Compass |
| _____ Pencil | _____ Ruler |
| _____ Orbit® Pressure Gauge | _____ String |

Layout Graph Paper

100

90

80

70

60

50

40

30

20

10

0

10

20

30

40

50

60

70



Graph Scale □ = 1/10" or 1' □□□□□□□□ = 1" or 10'

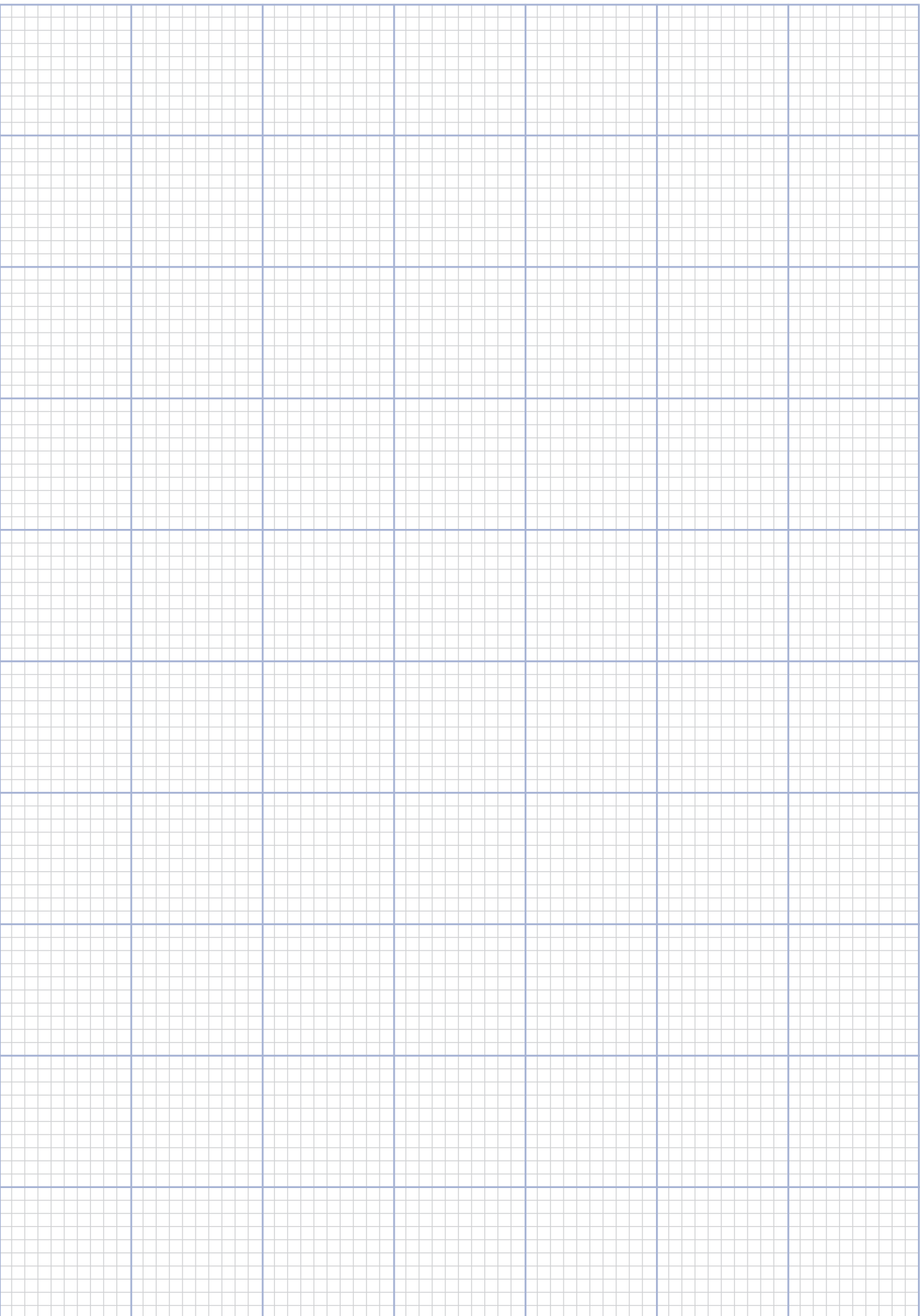

0 80 90 100 110 120 130 140

Installing Your Sprinkler System

Helpful Tools

Installation

- | | |
|--|---|
| <input type="checkbox"/> Ground Paint | <input type="checkbox"/> Orbit® Sprinkler Flags |
| <input type="checkbox"/> Shovel | <input type="checkbox"/> Orbit® Pipe Cutting Tool |
| <input type="checkbox"/> Screw Driver | <input type="checkbox"/> Adjustable Pliers |
| <input type="checkbox"/> Pipe Wrench | <input type="checkbox"/> Hacksaw |
| <input type="checkbox"/> Wire Cutter/Striper | <input type="checkbox"/> Thread Seal Tape |

INSTALLATION

1

This section will show you how to install your sprinkler system.

SYSTEM LAYOUT

2

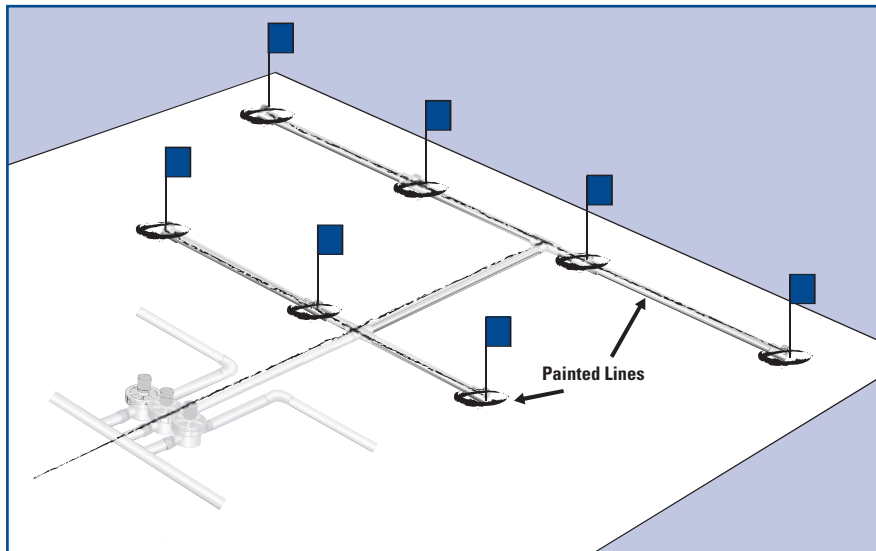

Marking Head and Pipe Location

Begin by marking the entire layout

- Use Orbit® sprinkler flags to mark each head.
- Use ground paint to mark where sprinkler pipes will run.

Important:

- Refer to your local code information for any regulations about connecting to the water main.
- Before digging, contact utility companies and have them mark utility lines.
- Obtain permits (if required).
- Always use gloves and safety goggles when installing.

CONNECT TO WATER MAIN

3

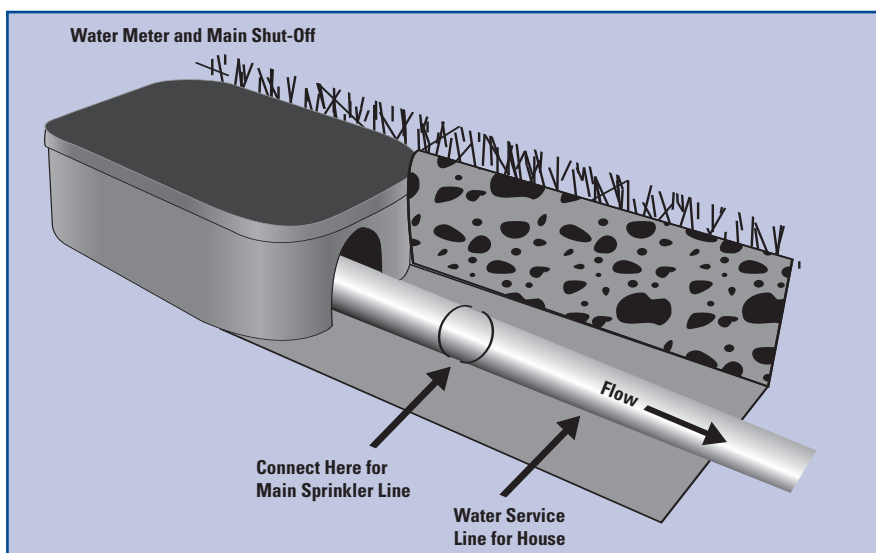

Dig Access Hole

1. Dig to expose the water service line (downstream from the meter).
2. Shut off the main water supply (located next to the meter).
3. Open a faucet to relieve pressure in the pipes.

Connect to Main Line

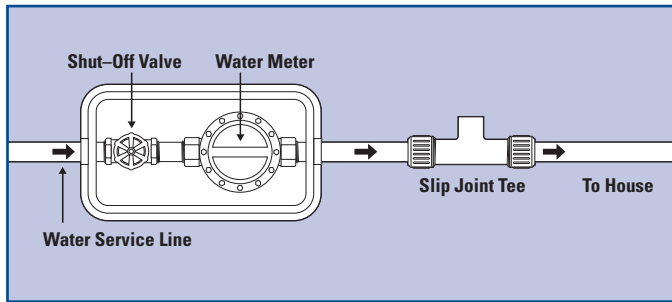

Install a Slip Compression Tee

- Clean off the water service pipe (downstream from meter).
- Cut out a section of pipe – half the length of the tee.
- Install nuts and washers on each side of the pipe.
- Insert the slip joint tee and tighten the nuts with a wrench.

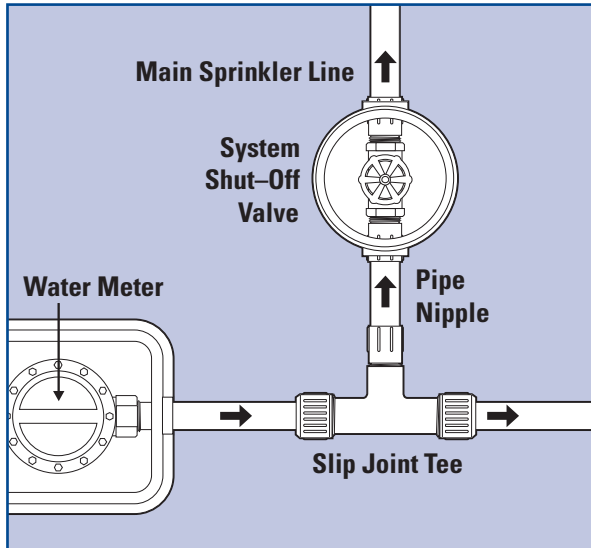

Shut-Off Valve – Non-Freezing Area

Install a Gate or Ball valve after the tee and cover it with an Orbit® valve box to protect it and for easy access to the valve.

- Use fittings to install a Gate or Ball valve on the tee.
- Turn on water to flush line of debris.
- Cover with an Orbit® valve box.

Important: Frost Areas or Basement Located Water Meters

Do not use the example above if you are connecting to a water supply line that is located in an area with freezing temperatures or a line that has a water meter located in the basement.

For help in making the proper connections go to www.orbitonline.com for detailed recommendations or contact your home improvement center.

BACKFLOW PREVENTION

4

Install a back-flow prevention device (if required). Use local code information to determine:

- What type of device is required
- How it needs to be installed
- Who is authorized to install it

DIG TRENCHES

5

Using the painted lines as your guide (see System Layout, Page 13) dig trenches to the depth required by local codes.

Important: Refer to your local codes to determine how deep your header and lateral lines need to be. Always contact your local utility companies before digging.

Methods for Digging Trenches

- **By Hand** – Ideal for soft soils and very small jobs
- **With Trenching Machine** – Available at equipment rental dealers

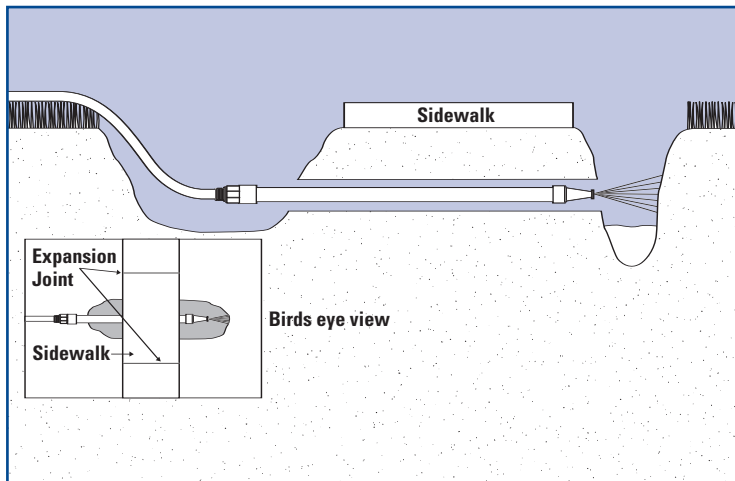

Under Driveways and Sidewalks

Use an Orbit® Walkway Tunnel Kit (part # **OP-53333**) to tunnel under obstacles.

- Dig a trench on both sides.
- Attach a garden hose to the tunneling pipe.
- Turn on the garden hose faucet.
- Work the pipe back and forth, allowing the water spray to form a tunnel.

WORKING WITH PIPE

6

Decide whether you'll use PVC or Polyethylene pipe for your system. Both types are easy to use, but they are assembled differently. Read about each type below to make your selection.

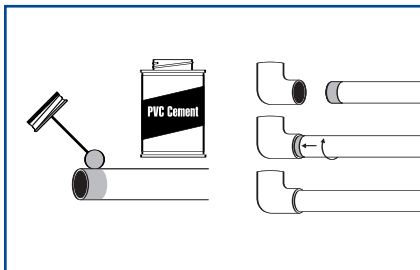

Working with PVC Pipe

- Using an Orbit® cutting tool, cut pipe to length and clean the end.
- Apply PVC primer and PVC cement, using instructions provided.
- Insert pipe into fitting.

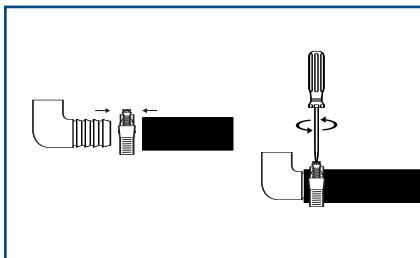

Working with Polyethylene Pipe

- Using an Orbit® cutting tool, cut poly-pipe to length.
- Slide a stainless steel clamp over the end of the pipe.
- Insert a barbed fitting into the pipe.
- Tighten the clamp over the pipe and fitting.

Warning: Poly pipe should not be used for the main line to the manifold.

INSTALL MAIN LINE

7

Use PVC schedule 40 (or other pressure-rated pipe) to connect the main shut-off valve to the valve manifold(s).

Important: Use pipe one size larger than your supply line. Using pipe smaller than the main supply line will reduce your water flow and will lead to gaps in spray coverage. (For example, use 1" pipe if your supply line is 3/4")

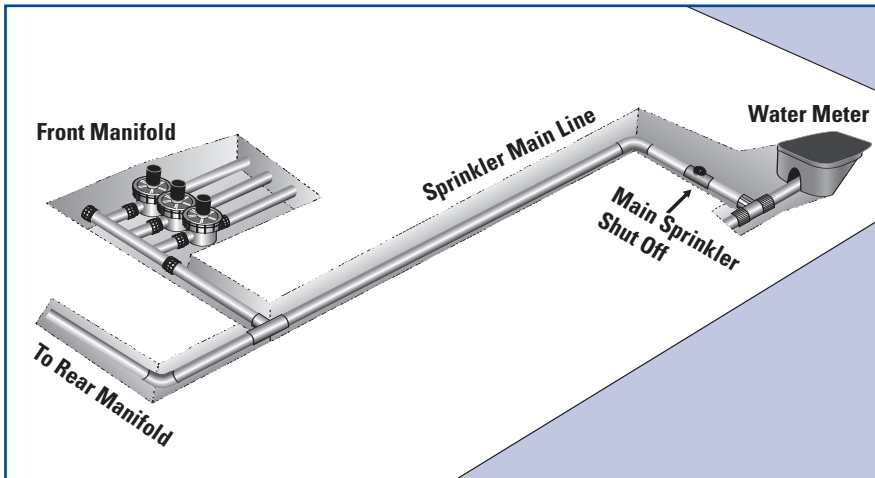

Installing main line pressure-rated pipe to front and back manifold

INSTALL MANIFOLD

8

The easiest way to install a manifold is with an Orbit® Pre-Assembled Manifold. Purchase a manifold with one valve for each sprinkler zone.



- Installs in minutes
- Works with both Poly-Pipe and PVC Systems
- Cost effective
- Expandable for future sprinkler additions

Note: Anti-siphon pre-assembled manifolds are available for areas requiring use of an anti-siphon valve

Pre-Assembled Manifold **OV-91206-NEW OR OV-91207-NEW**

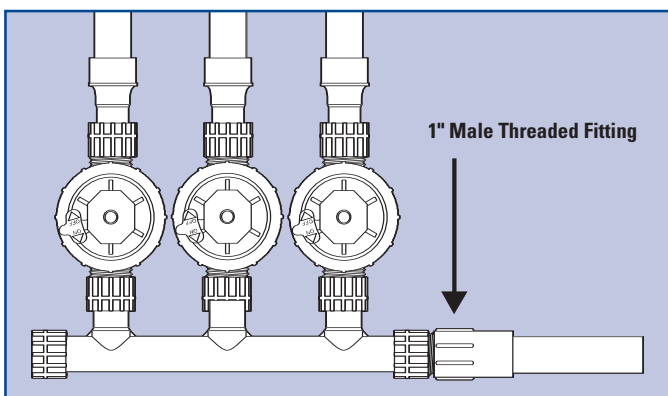

Connecting the Manifold to the Main Line

- Before connecting the manifold, open the main shut-off valve to flush dirt from the main sprinkler line.
- Connect the Pre-Assembled Manifold to the main sprinkler line using a 1" threaded fitting.

CONNECT ZONES

9

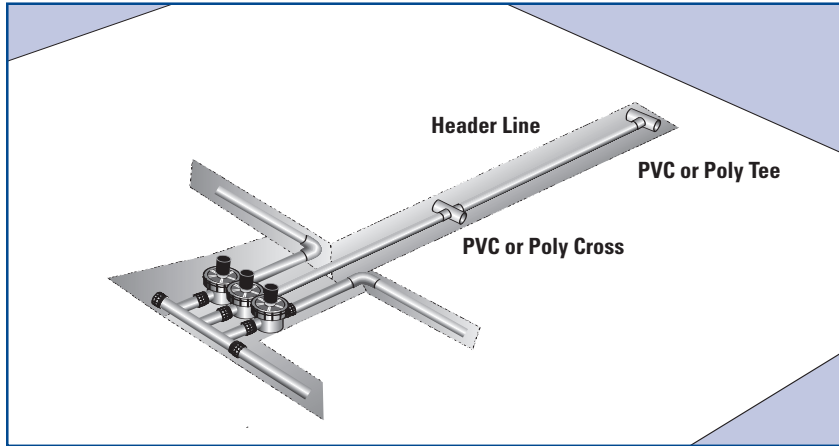

Install Header Lines

- Connect 1" pipe to each valve and run it to the assigned zone.
- Use fittings (elbow, cross or tee) for each lateral line.

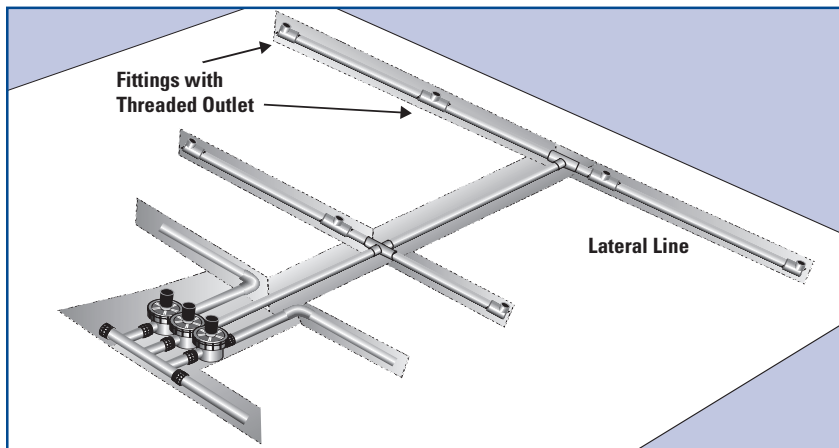

Install Lateral Lines

- Connect 3/4" lateral lines to the header line.
- Run lateral line to each sprinkler location.
- Install Tees or Elbow at each sprinkler location.

Freezing Areas – Install Line Drains

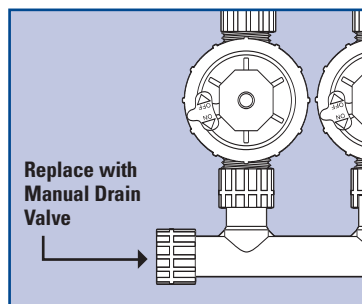
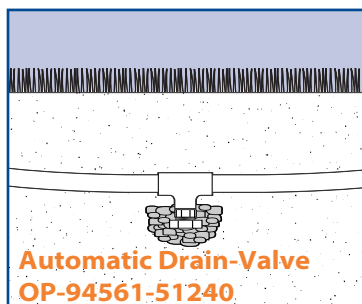
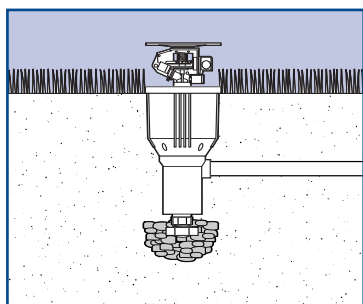

Lateral and Header Lines

Canister Heads: Install an automatic drain valve in the bottom inlet of all canisters.

End of Sprinkler Line: Install an automatic drain valve after the last head on the end of each sloped line.

Low Spots: Install a tee and automatic drain valve for low spots on sprinkler head lines.

Main Line

Manifold: Remove the end cap and install a ball or gate manual drain valve.

INSTALL RISERS & HEADS

10

Install Risers (Without Heads)

Risers are designed to bring the sprinkler head up to ground height. A wide selection of risers are available. Select the riser that best fits your needs.

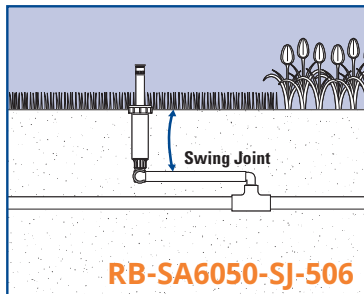

RB-SA6050-SJ-506

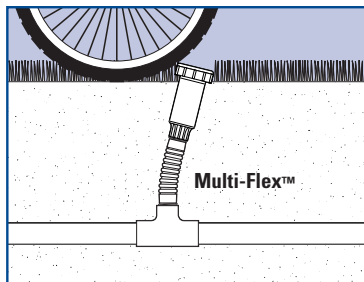

Multi-Flex™

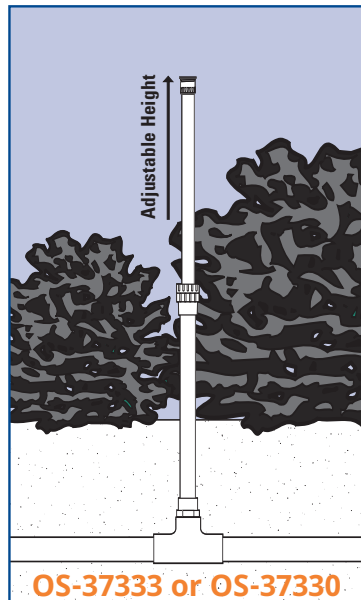

OS-37333 or OS-37330

Swing Joints & Riser Flex

- Easy to adjust sprinkler height
- Resists impact and cracking
- Useful for placing heads in hard to reach areas

Multi-Flex™ Risers

- Comes in various lengths
- Deflects impact

Aluminum Riser with Adjustable Nozzle

- Adjusts in Height as Plant Grows – 16" to 30"
- Easy Pattern Adjustment – 25° to 360°

Flush Sprinkler Lines – Prior to Installing Heads

- Ensure PVC glue has dried adequately.
- Turn on the main line sprinkler valve.
- Manually turn on one valve at a time (see valve instruction booklet).
- Run each valve for a few minutes.

Installing Heads and Testing

- Attach sprinkler heads to each riser and adjust the height to proper level.
- Place enough soil in the trench to stabilize heads but don't fill the trench.
- Manually turn on one valve at a time.
- Check for leaks.

Important: Adjust heads for proper spray pattern and check for adequate head to head coverage.

CONNECTING SPRINKLER WIRE

11

Sprinkler wire consists of one white (common) and 4 or 6 colored strands. The sprinkler wire needs to have at least one more wire strand than the number of valves being installed.

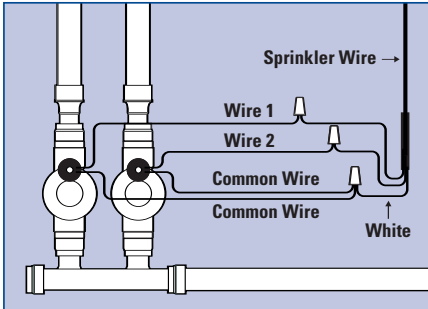

Wiring the Valves

Using wire nuts and grease caps, connect the wires as shown:

- Connect one wire from each valve to the white (common) sprinkler wire.
- Connect the 2nd wire from each valve to a separate color wire.

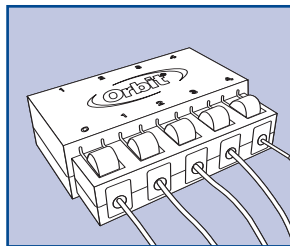
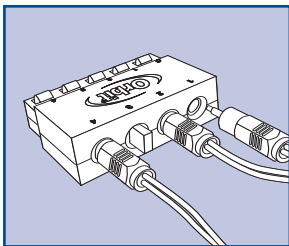

Tip: Orbit's® Pre-Assembled Manifold with Snap-Wire™ Connection makes wiring valves easy. Just plug in the valve jack into the water-tight Snap-Wire™ housing and insert sprinkler wire into the other side. No confusing wiring or messy grease caps (see page 22 for more info).

Run Sprinkler Wires to Timer

Most often you can use an existing sprinkler pipe trench to run your sprinkler wire. In areas of frequent digging, a conduit pipe is used to protect the wire.

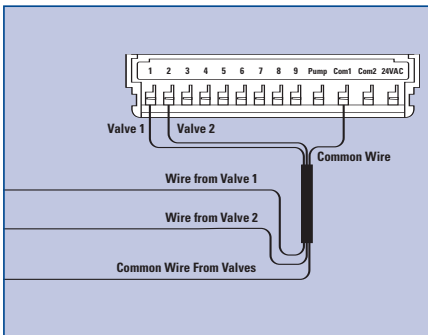

Wiring Your Sprinkler Timer

- Unplug your timer from the power source (if hard wired turn off appropriate breaker switch or remove fuse).
- Connect each colored sprinkler wire to a separate numbered terminal (on the timer).
- Connect the white (common) wire to the common terminal on the timer.
- Restore power to your timer.
- To test proper wiring, manually run each station from the timer.

BURYING SPRINKLER PIPE AND VALVES

12

Before Burying Trenches:

1. Check all fittings, heads and valves for leaks.
2. Adjust sprinkler height to proper level.
3. Adjust each head for proper spray pattern and spray distance. (Use your drawings as a reference.)
4. Cover manifolds with an Orbit® valve box.

APPENDIX

A

Chart 1

QUICK REFERENCE – MAXIMUM HEADS PER ZONE ESTIMATES						
MAIN LINE SIZE SCH. 40 PVC	WATER PRESSURE (PSI)					
	30 PSI	40 PSI	50 PSI	60 PSI	70 PSI	80 PSI
3/4"	Gear Drive					
	Voyager II® *	1	2	2	3	4
	Saturn III® *	2	2	3	4	5
	Impact Sprinklers					
	Satellite®**	1	2	2	3	4
	1/2" Brass	1	1	2	2	3
	Pop-Up & Shrub Spray Head					
	Adjustable & Fixed**	4	5	6	7	8
	Strip Pattern	3	4	4	6	7
	Shrub Bubbler					
	Mushroom Bubbler***	4	6	8	10	13
	Gear Drive					
	Voyager II® *	2	2	3	4	5
	Saturn III® *	3	3	4	5	6
Impact Sprinklers						
Satellite®**	2	2	3	4	5	
1/2" Brass	1	1	2	3	4	
Pop-Up & Shrub Spray Head						
Adjustable & Fixed**	4	5	7	9	10	
Strip Pattern	3	4	5	7	8	
Shrub Bubbler						
Mushroom Bubbler***	6	8	10	14	16	

* With pre-installed nozzle

** Based on an average flow rate of 1.6 GPM per head

*** Adjustment set below 1/2 flow

Important: These figures are based on a typical sprinkler system. Before burying sprinkler pipe, run each zone to confirm adequate spray coverage.

Chart 2

SPRINKLER HEAD TO HEAD SPACING GUIDE	
LARGE AREA SPRINKLERS	
Gear Drives	
Voyager II® *	20' – 40'
Saturn III® *	15' – 30'
Impact Sprinklers	
Satellite® *	20' – 40'
1/2" Brass Impact *	25' – 45'
MEDIUM AREA SPRINKLERS	
Pop-Ups	
Adjustable Nozzle	10' – 15'
Fixed Nozzle	10' – 15'
SHRUB AND FLOWER	
Bubbler	
Bubbler	Spot

* Spray distance adjusted by diffuser pin

Important: Before burying sprinklers, check for head to head spray coverage. Adjust if necessary.

Chart 3

VOYAGER II® POP-UP GEAR DRIVE HEAD					
NOZZLES	30 PSI	40 PSI	50 PSI	60 PSI	70 PSI
1	.5	.6	.7	.8	–
2	.7	.8	.9	1.0	–
3	.9	1.0	1.2	1.3	–
4	1.2	1.4	1.6	1.8	–
5	1.6	1.8	2.0	2.2	–
6	2.0	2.4	2.7	2.9	–
7*	2.6	3.0	3.4	3.7	–
8	3.2	3.7	4.2	4.6	–
9	4.2	4.9	5.5	6.0	–
10	–	6.0	6.8	7.6	8.2
11	–	8.0	8.9	9.8	10.5
12	–	11.4	12.2	13.2	14.4

* Factory installed 7" nozzle
Spacing 20' - 45'

SELECTING THE BEST COMPONENTS FOR YOUR SPRINKLER SYSTEM

A

Sprinkler Timers

The timer is the brains for your underground sprinkler system that controls when and how long to irrigate your yard. Orbit's® line of timers are known for reliability, ease of installation, programming simplicity and a 6 year warranty, making *Orbit® Timers the #1 choice by homeowners.*



Slide Switch

The easiest timer to program, with water saving features.

- **Large Display with Text Messaging** – Easy to program, easy to use
- **3 Independent Programs** – Days of Week, Watering Intervals and Odd/Even Days
- **Water Saving Features** – Water Budgeting, Rain Delay & Rain Sensor ports
- **Slide Switch Feature** – One-Touch sliding bar adjusts each station watering duration. Ideal for lawn and micro-irrigation.
- **Pump or Master Valve Feature**

Available in 4, 6, 9 & 12 Stations
Outdoor version available



Super Dial

- **Large Dial and Buttons** – Simplify programming
- **2 Independent Program** – Days of Week, Watering Intervals and Odd/Even Days
- **Rain Delay** – Settings for 24, 48 and 72 hours
- **Screw-Less Terminals** – No tools required
- **Pump or Master Valve Feature**
- **Up to 8 Start Times Per Day** – Ideal for new lawn and reducing run-off

Available in 4, 6, 9 & 12 Stations
Outdoor version available



Dual Program

- **Easy to Program**
- **2 independent programs** – Days of the week and Watering intervals
- **Water-Saving Rain Delay Feature** – Settings for 24, 48, and 72 hours
- **Up to 8 Start Times Per Day** – Ideal for new lawn and reducing run-off

Available in 4 and 6 Stations



Dual Program With Wireless Remote

Same features as the Dual Program timer with the addition of Wireless Remote

- **Time Saver** – Ideal for installation, testing, maintenance, and sprinkler adjustments
- **Allows Operation of Individual Stations** – Up to 200 feet

6 Stations only

Pre-Assembled Valve Manifolds

Orbit® valves continue to set a high ground for solid construction and reliability.

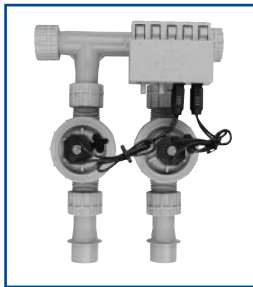

Pre-Assembled Manifolds with Snap-Wire™

- The most complete and reliable multi-valve system
- Installs in minutes
- Snap-Wire™ plug-in system simplifies wiring
- Works with PVC or Poly-Pipe
- 6 Year Warranty

Available:

- **Standard Inline** – 2 and 3 valves
- **Anti-Siphon** – 2 valves

Spring-Loaded Pop-Ups with Adjustable Nozzle



A Standard Top – The standard plastic cap with an adjustable nozzle offers convenience, ease and value for the homeowner. “Just set and Forget.”

B Soft Top™ – The Soft Top adds a soft cushioned rubberized cap.

C Hard Top™ – The Hard Top adds a metal cap for high traffic areas, such as driveways and sidewalks, where sprinklers are subject to contact with vehicles and yard equipment.

Features

- **Easy to Adjust Spray Pattern** – 25° to 360°
- **Spacing** – 10' to 15'
- **Available in 2" and 4" Pop-Up Height**
- **5 Year Warranty**

Voyager II® & Saturn III® Gear Drives



The #1 Choice by Homeowners

- **Simple Pattern Adjustment** – 40° to 360°
- **4" Pop-Up Height** – Clears long grass
- **Easy to Adjust Spray Distance** – 20' to 40' Voyager II®, 15' to 30' Saturn III®
- **Quiet and Smooth Rotating Spray**
- **5 Year Warranty** – Dependable and trouble-free performance
- **Additional Nozzle Sizes Available** – 20 for Voyager II® and 3 for Saturn III®

Voyager II®: Part # OR-94161-55661; Saturn III®: Part # OR-94214T Saturn Ultra-Pro Part OR-SATURN-PRO



Orbit® Valve Box

Durable long lasting construction

Available:

- 20" Jumbo Rectangle Box
- 12" Standard Rectangle Box
- 10" Round Box
- 6" Round Box
- 32" to 54" Adjustable Curb Box

PARTS LIST

A

Automatic Timers & Pump Start Relay		
Part #	Description	Qty
	6 Station Slide Switch	
	12 Station Slide Switch	
	6 Station Super Dial	
	9 Station Super Dial	
	6 Station w/ Wireless Remote	
	4 Station Dual Program	
	Pump Start Relay	
Pre-Assembled Manifolds		
Inline		
57150	2 Valve with Snap-Wire™ Connection	
57153	3 Valve with Snap-Wire™ Connection	
Anti-siphon		
57172	2 Valve Anti-Siphon	
Automatic Valves		
Inline		
57467	1" Male Threaded Jar Top	
57461/57661	1" Female Threaded Jar Top	
57100	3/4" Threaded	
57101	1" Threaded	
Anti-siphon		
57623	3/4" Anti-siphon Threaded	
57624	1" Anti-siphon Threaded	
Backflow Valve		
51050	3/4" Double Check Valve	
51057	3/4" Pressure Vacuum Breaker	
Valve Boxes		
53210	6" Circular	
53211	10" Circular	
53212	12" Standard Rectangle	
53029	32" to 54" Adjustable Curb Box	
Tools		
53020	Orbit® pressure gauge	
26085	Pipe cutting tool	
53326	Sprinkler flags	
53333	Walkway tunnel kit	
Accessories		
51040	1/2" Plastic Automatic Drain Valve	
53266	28" Curb Key	
53034	5' Steel Curb Key	

* Outdoor models

Sprinkler Wire		
Part #	Description	Qty
57088	7 Conductor 100' – For up to 6 Valves	
57093	5 Conductor 100' – For up to 4 Valves	
Sprinklers		
Large Area		
55060/55061	Voyager II® Gear Drive	
55059/55069	Saturn III® Gear Drive	
55012	Satellite® Pop-Up Impact	
Medium Area – Spring Loaded Pop-Ups		
Spring-Loaded Pop-Up w/ Adjustable Pattern		
54115	2" Hard Top™	
54118	4" Hard Top™	
54113	2" Soft Top™	
54114	4" Soft Top™	
54116	2" Standard	
54117	4" Standard	
Spring-Loaded Pop-Up w/ Fixed Pattern		
54016	2" Full Pattern	
54017	2" Half Pattern	
54018	2" Quarter Pattern	
54127	2" Center Strip	
Small Area		
54042	Mushroom Bubbler	
37330	Aluminum Riser 16" to 30" with Adjustable Nozzle	
Riser Flex and Swing-Joints		
37264	1/2" x 1/2" x 12" Pre-Assembled Swing Joint	
37265	3/4" x 1/2" x 12" Pre-Assembled Swing Joint	
37163	1/2" Male x Female Swing Joint Elbow	
37164	3/4" Male x Female Swing Joint Elbow	
37159	1/2" Male x Barb Elbow – Riser Flex	
37162	3/4" Male x 1/2" Barb Elbow – Riser Flex	
37154	1/2" x 50' Riser Flex Pipe	
Multi-Flex® Riser & Cut-Off Riser		
37112	1/2" x 6" Multi-Flex®	
37069/38500	1/2" x 6" Cut-Off	



Parts List			
Photos	Descriptions	Part #	Qty
	Orbit® Eco-Spray Sprinklers : Model Less Nozzle - 4" Pop-up (10 cm)	OS-ECOSPRAY	
	Orbit® Spray Sprinklers : Model Less Nozzle - 4" Pop-up (10 cm)	OS-54457	
	Orbit® Adjustable Arc Nozzles : 8' radius (2,4 m)	OS-53889	
	Orbit® Adjustable Arc Nozzles : 10' radius (3,0 m)	OS-53878	
	Orbit® Adjustable Arc Nozzles : 12' radius (3,7 m)	OS-53483	
	Orbit® Adjustable Arc Nozzles : 15' radius (4,3 m)	OS-53484	
	Orbit® Adjustable Arc Nozzles : 17' radius (4,3 m)	OS-53485	
	Orbit® Saturn Ultra-Pro Rotary Sprinklers - Radius 15' to 24'	OR-SATURN-PRO	
	Orbit® Voyager II Professional Rotary Sprinklers - Radius 22' to 32'	OR-94161-55661	
	Orbit® Saturn III Rotary Sprinklers - Radius 15' to 24' (4,6m to 7,3m)	OR-94214T	
	Orbit® Saturn III Nozzle Set: Nozzle Set for Orbit Saturn III Rotors	OR-55075	
	Orbit® Rain Sensor	OA-57069-91069	
	Orbit® Wireless Rain/Freeze Sensor	OA-57071	
	7 in. NDS Round Valve Boxes : For 1 valve	VB-NDS-07	
	10 in. NDS Round Valve Boxes : For 2 valves	VB-NDS-10	
	12 in. x 17 in. x 6-3/4 in. NDS Rectangular Valve Boxes : For 4 valves	VB-NDS-1217	
	15 in. x 21 in. x 6-5/8 in. NDS Rectangular Valve Boxes : For 5 valves	VB-NDS-1521	



Parts List			
Photos	Descriptions	Part #	Qty
	Direct Burial Multiconductor Irrigation Wire : 18/2 Multistrand wire	E-18/02	
	Direct Burial Multiconductor Irrigation Wire : 18/5 Multistrand wire	E-18/05	
	Direct Burial Multiconductor Irrigation Wire : 18/7 Multistrand wire	E-18/07	
	Direct Burial Multiconductor Irrigation Wire: 18/10 Multistrand wire	E-18/10	
	Direct Burial Multiconductor Irrigation Wire: 18/12 Multistrand wire	E-18/12	
	Orbit® Pro Connectors	E-57905	
	Orbit®/Hydro-Rain Flexible Pipe Cutting Tool	O-26113	
	Orbit® Pressure Gauge : 91130 Model	O-91130	
	Oetiker 1098 8 in. Pinch Clamp Crimping Tool	O-1098	
	Orbit® 2 Valves Preassembled Manifold with 3/4" Poly Pipe Outlets	OV-91206-NEW	
	Orbit® 3 Valves Preassembled Manifold with 3/4" Poly Pipe Outlets	OV-91207-NEW	
	Orbit® Heavy Duty 3/4" Poly-Pipe Adapter : 3/4 In. Poly Adapter	OP-57188-91329	
	Orbit® Heavy Duty 3/4" Poly-Pipe Adapter : 3/4 In. Poly Adapter	OP-57189	
	Irrigation Crimp Clamps : 3/4"	P-OE-271R	
	Irrigation Crimp Clamps : 1"	P-OE-331R	



PN 53251 Rev E



Irrigation Products, Inc.
845 North Overland Road
North Salt Lake, Utah 84054 USA

www.orbitonline.com
Toll-Free 1-800-488-6156
Phone 801-299-5555
Fax 801-299-5547

